



LINEA BAR
BAR LINE



FRP

frappè

drink mixers

- Famiglia completa di macchine per il frappè caratterizzato da linee morbide e precise. Studiato per un utilizzo professionale e severo nel rispetto delle norme di sicurezza europee e nordamericane.
- Corpo macchina bianco o cromato, colonna in alluminio estruso e base in pressofusione per una ottima stabilità della macchina, il tutto privo di angoli e giunzioni per facilitare la pulizia.
- Disponibile nella versione da banco 1 o 2 bicchieri o a parete.
- Bicchiere da 550 cc in Tritan (BPA Free) trasparente o a richiesta in acciaio inox.
- Bicchiere da 900 cc in acciaio inox su versione da 120 watt.
- Motore potente e ventilato per una maggiore durata.
- Versione con 3 fruste in alluminio e acciaio per la preparazione di frappè e sorbetti o con disco appositamente studiato per il caffè shakerato o per montare il prodotto in lavorazione.
- Microinterruttore di sicurezza sul bicchiere (opzionale per paesi extra UE).
- Variatore di velocità a richiesta.

- *A complete line of drink mixers with a soft design. Designed to commercial use, they meet all European and North-American safety requirements.*
- *White or chrome head, aluminium stem and die casting base for a perfect stability, no edges or seams for easier cleaning.*
- *Countertop (1 or 2 cups) or wall unit versions available.*
- *Transparent 550 cc Tritan (BPA Free) cup or stainless steel cup on request.*
- *900 cc stainless steel cup on 120 W version.*
- *Powerful ventilated motor for a longer life.*
- *Spindle with three aluminium and s/steel agitators for preparing milkshakes and drinks, or with a special round agitator for frozen coffees or for creamier results.*
- *Safety microswitch on the cup support (optional for non UE countries).*
- *Speed control on request.*



FRP 1 VV



FRP 1 VV - 120W 900CC



FRP 2 VV



FRP 2



FRP CAFFÈ



Particolare fruste FRP 120W
FRP 120W agitators



Opzionale: Anello portabicchieri usa e getta
Optional: ring for paper cups

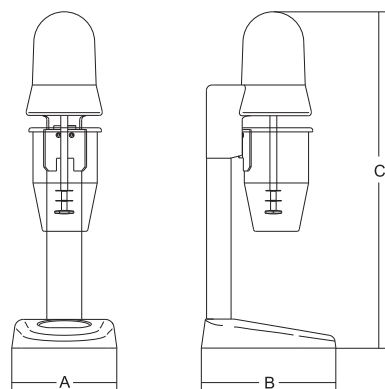

	watt/HP	r.p.m.	lt	mm	mm	mm	kg	mm	kg	
FRP 1	100/0.14	1ph	14.000	0.55	150	195	485	2.5	210x250x520	3.5
FRP 2	100+100/0.14+0.14	1ph	14.000	0.55x2	300	195	485	5	370x260x530	6.5
FRP 1P	100/0.14	1ph	14.000	0.55	110	150	360	2	190x240x510	4
FRP 1 VV	100/0.14	1ph	4.000÷14.000	0.55	150	195	485	2.5	210x250x520	3.5
FRP 2 VV	100+100/0.14+0.14	1ph	4.000÷14.000	0.55x2	300	195	485	5	370x260x530	6.5
FRP 1P VV	100/0.14	1ph	4.000÷14.000	0.55	110	150	360	2	190x240x510	4
FRP 1 - 120W 900cc	120/0.16	1ph	14.000	0.9	150	195	530	3	210x250x560	4.5
FRP 1 VV - 120W 900cc	120/0.16	1ph	4.000-14.000	0.9	150	195	530	3	210x250x560	4.5
FRP 2 - 120W 900cc	120+120/0.16+0.16	1ph	14.000	0.9x2	300	195	530	6	360x250x560	7
FRP 2 VV - 120W 900cc	120+120/0.16+0.16	1ph	4.000-14.000	0.9x2	300	195	530	6	360x250x560	7



FRP 1



FRP 1P VV



FRP 1P

FE

frullatori blenders

- Frullatore nato dalle specifiche esigenze del bar moderno, particolarmente adatto per preparare frullati e bevande di frutta e verdura.
- Corpo macchina bianco o cromato, privo di angoli e giunzioni per facilitare la pulizia.
- Motore ad elevata potenza con ventilazione forzata.
- Bicchiere da 1,5 litri in Tritan (BPA Free) trasparente infrangibile, lavabile in lavastoviglie, graduato in litri e galloni UK e USA.
- Coperchio bicchiere in gomma a perfetta tenuta con tappo e bicchierino graduato per l'aggiunta degli ingredienti durante la lavorazione.
- Sistema di trasmissione con denti contrapposti in metallo e gomma per una elevata trasmissione della potenza e bassa rumorosità.
- Coltello a 4 razze ricavato da un unico stampaggio, in acciaio inox da coltelleria facilmente smontabile.
- Microinterruttore di sicurezza sul coperchio bicchiere.
- Variatore di velocità a richiesta.

- *Designed to meet the specific needs of the modern bar, it is particularly suitable for preparing smoothies, fruit and vegetables drinks.*
- *White or chrome body, no edges or seams for easy cleaning.*
- *Powerful ventilated motor.*
- *Transparent, unbreakable 1,5 lt Tritan (BPA Free) container is dishwasher safe and graduated with litres and UK/USA gallons.*
- *Tight rubber lid with feed opening to add ingredients while the blender is working.*
- *Metal and rubber gears drive gives a high power transmission and quiet operation.*
- *4-blades stainless steel knife can be easily disassembled.*
- *Safety microswitch on the lid.*
- *Speed control on request.*



Modello caffè
Coffee model









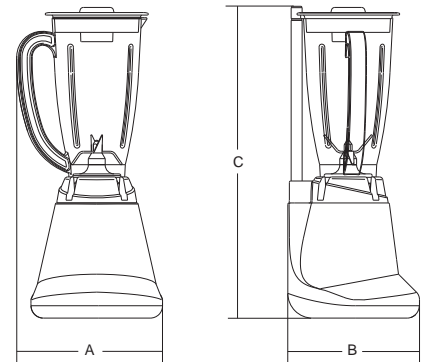



Micro su coperchio
Microswitch on cover



Modello VV: variatore di velocità
Speed control optional



										
	watt/HP	r.p.m.	lt	mm	mm	mm	kg	mm	kg	
FE	450/0.60	1ph	16.000	1.5	213	200	416	3	310x300x530	4
FE VV	450/0.60	1ph	11.000÷16.000	1.5	213	200	416	3	310x300x530	4

F

frullatori *blenders*



F Q VV



F T VV



- Frullatori professionali nati dalle specifiche esigenze del bar, ristorante, mensa, ecc.
- Corpo macchina in alluminio estruso e fianchi in ABS.
- Sistema di tenuta a membrana per prevenire l'ingresso di liquidi all'interno della macchina.
- Potente motore con ventilazione forzata, per un utilizzo prolungato e una maggiore durata.
- Microinterruttore magnetico di sicurezza sul coperchio bicchiere senza posizione obbligatoria.
- Comandi a membrana silconica con pulsante ON, OFF Pulse e dispositivo NVR.
- Variatore di velocità.
- Coperchio bicchiere in gomma con tappo per l'aggiunta di ingredienti.
- Corpo mozzo di trasmissione in acciaio inox, facilmente separabile dal corpo bicchiere per una facile pulizia.
- Albero coltelli supportato da cuscinetti a sfere per prevenire il surriscaldamento e garantire una lunga durata.
- Trascinatore a stella in acciaio sinterizzato ad alta resistenza.
- Coltello a 4 razze ricavato da un unico stampaggio in acciaio da coltelleria temperato adatto anche per tritare ghiaccio.

MODELLO Q

- Bicchiere quadro da 2 litri in Tritan (BPA Free), graduato in litri, galloni UK e USA.
- Il bicchiere quadro è stato sviluppato per lavorare al meglio con grandi quantità di ghiaccio anche a secco, pratico e funzionale, si può versare il prodotto su 3 diverse direzioni.
- Ideale per la preparazione di frozen drink o smoothies con sciroppi e concentrati.

MODELLO T

- Bicchiere tondo da 2 litri in Tritan (BPA Free), graduato in litri, galloni UK e USA, ideale per frullati e frozen.
- Optional: bicchiere inox da 2 litri, ideale per frullati e frozen.

ALTRI MODELLI Q/T

- Modello 2 bicchieri in Tritan o inox opzionale.
- Modello Timer: timer a regolazione manuale e spegnimento automatico della macchina.
- Modello Plus: versione elettronica con 9 programmi di lavorazione preimpostati.

MODELLO 5 LITRI

- Corpo macchina in acciaio inox.
- Bicchiere tondo in acciaio inox da 5 litri.
- Coperchio bicchiere in PE e guarnizione di tenuta, bloccato con cerniere, tappo per l'aggiunta di ingredienti.
- Albero coltelli supportato da boccole in bronzo.
- Trascinatore metallico con denti contrapposti ideale per resistere alle lavorazioni con prodotti caldi.

- Professional mixer designed to cater for specific requirements of bars, restaurants, cafeterias, etc.
- Extruded aluminium machine body and sides in ABS.
- Membrane sealing system to prevent fluids from entering the machine.
- Powerful motor with forced ventilation, for prolonged use and enhanced durability.
- Magnetic safety micro-switch on glass lid without forced position.
- Siliconic membrane controls with ON, OFF Pulse button and NVR device.
- Speed control.
- Glass lid in rubber with plug for adding ingredients.
- Stainless steel transmission hub body; can be easily separated from the glass body for easy cleaning.
- Cutters shaft supported by ball bearings to prevent overheating and to guarantee enhanced durability.
- Star drive in high-resistance sintered steel.
- 4-Spoke cutter obtained from a single pressing of hardened steel for blades also suitable for crushing ice.



F 2T VV

F 2Q VV

Q MODEL

- 2 litre square glass in Tritan (BPA Free), graduated in litres, UK and U.S. gallons.
- Very practical square glass, with possibility of pouring in 3 different directions, ideal in the preparation of frozen drinks, Smoothies with syrups and concentrates.
- Ideal in the preparation of frozen drinks, Smoothies with syrups and concentrates.

T MODEL

- 2 litre round glass in Tritan, graduated in litres, UK and U.S. gallons, ideal for shakes and frozen drinks.
- Optional: round 2-litre glass, made in stainless steel, ideal in the preparation of shakes and frozen drinks.

OTHER MODELS Q/T

- 2 glass version, for T/Q models, in Tritan (BPA Free) or stainless steel optional.
- F Timer: manual adjustment timer and automatic machine switch-off.
- F Plus: electronic version with 9 pre-set processing programs.

5 LITERS MODEL

- Machine body in stainless steel.
- 5-Litre round glass in stainless steel.
- Glass lid in PE and sealer, locked with hinges and with plug for adding ingredients.
- Cutters shaft supported by bronze bushes.
- Metal driver with opposing teeth, ideal to withstand processing of hot products.



F FIVE



BMS

frullatori

blenders



BMS T Wi-Fi

BMS Q Wi-Fi

TOUCH WI-FI

- Dotato di facile e intuitivo controllo touch
- Tastiera IP 67 ad azionamento veloce
- 8 programmi su scheda a partenza immediata
- Programmabili 8 diversi step su ogni programma
- Infiniti programmi scaricando l'APP gratuita
- Regolazione di velocità da 10 a 100%
- Funzionamento manuale
- Tasto Pulse per funzione rompigiaccio
- Segnali sonori di allarme regolabili
- Collegabile a Wi-Fi per una facile gestione dei programmi su diverse macchine
- Autodiagnostica di controllo per un immediato controllo dello stato della macchina
- Compatibile Industria 4.0

WI-FI TOUCH

- Fitted with easy and intuitive touch control display
- Fast action IP67 keypad
- 8 programmes on the card with immediate start
- 8 different settable steps in each programme
- Infinite programmes by downloading the free APP
- Speed regulation from 10 to 100%
- Manual operation
- Pulse key for ice-breaker function
- Adjustable audible alarm signals
- Can be connected to Wi-Fi for easy management of programmes on various machines
- Self-diagnostics for immediate check on the status of the machine
- Compatible with Industria 4.0



Comandi touch
Touch control



BMS T WI-FI
con campana silenziate opzionale
with sound enclosure, optional



BMS Q WI-FI
con campana silenziate opzionale
with sound enclosure, optional





Bicchieri in Tritan (BPA Free)
Glasses in Tritan (BPA Free)



Bicchieri tondo e quadro intercambiabili
Interchangeable round and square glasses



Lame in acciaio da coltelleria bicchiere tondo
Stainless steel blades for round glass



Lame in acciaio da coltelleria bicchiere quadro
Stainless steel blades for square glass



Bicchieri intercambiabili facilmente smontabili per la pulizia
Disassembled and interchangeable glasses, easy to cleaning



Bicchieri quadri impilabili
Stackable square glass



Applicazione frappè opzionale
Optional milkshakers application



Comandi VV
VV controls



Comandi Timer VV
Timer VV controls



Comandi Plus VV
Plus VV controls



Bicchiere tondo inox opzionale
Optional s/steel round glass

F

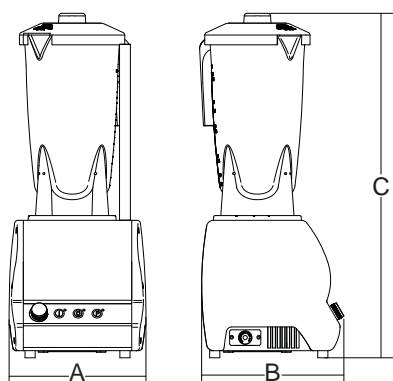

BMS

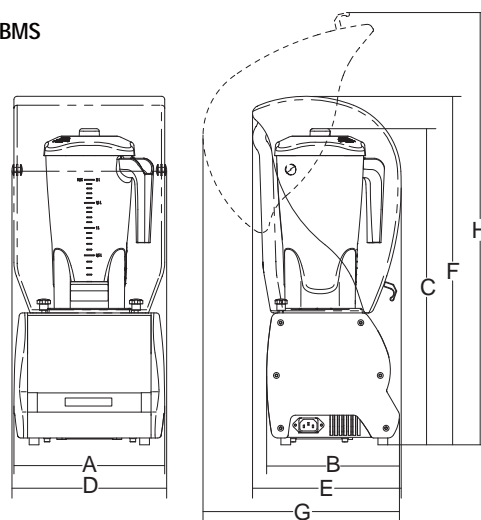

	watt/HP	r.p.m.	lt	mm	mm	mm	kg	mm	kg	
F Q VV	750/1	1ph	8.000 ÷ 16.000	2	202	210	486	5	310x300x530	7
F T VV	750/1	1ph	8.000 ÷ 16.000	2	202	210	508	5	310x300x530	7
F 2 Q VV	750+750/1+1	1ph	8.000 ÷ 16.000	2+2	380	210	486	10	480x300x530	12
F 2 T VV	750+750/1+1	1ph	8.000 ÷ 16.000	2+2	380	210	508	10	480x300x530	12
F Five VV	750/1	1ph	8.000 ÷ 16.000	5	245	260	540	7	340x330x640	9

	watt/HP	r.p.m.	lt	mm	mm	mm	mm	mm	mm	mm	mm	mm	kg	mm	kg
BMS Q Wi-Fi	750/1	1ph	8.000 ÷ 16.000	2	232	204	486	238	230	536	315	665	5	305x305x525	7
BMS T Wi-Fi	750/1	1ph	8.000 ÷ 16.000	2	232	204	508	238	230	536	315	665	5	305x305x525	7
Campana / Sound enclosure	-	-	-	-	-	-	-	-	-	-	-	-	1	305x305x525	2

ICE SPAGHETTI











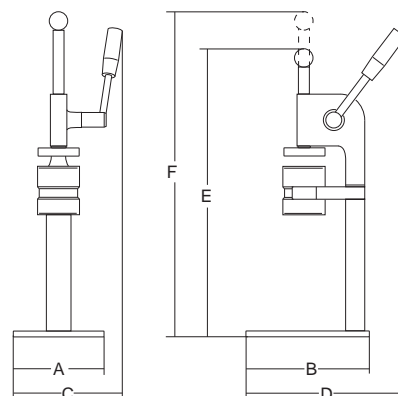

- Apparecchio con struttura in alluminio e cremagliera cromata, caratterizzato da un design lineare ed un funzionamento semplice. Dotato di particolari completamente smontabili per una pulizia più veloce ed accurata.
- Tre diversi bicchieri in alluminio lucidato, si possono realizzare coppe curate nei minimi particolari.
- Aluminium construction and chrome rack, feature a simple design and easy to use. Can be disassembled for a quicker and more accurate cleaning.
- Three different polished aluminium moulds, you can create elaborate ice-cream cups.



1. Spaghetti \varnothing mm 2,5
2. Tagliatelle mm 8x2
3. Asparagi \varnothing mm 15,5

1. Spaghetti \varnothing mm 2,5
2. Noodles mm 8x2
3. Asparagus mm \varnothing 15,5



										
	mm	mm	mm	mm	mm	mm	mm	kg	mm	kg
Ice Spaghetti	65x80	170	200	205	245	440	520	3,5	520x220x230	4

TRG-S

tritaggiaccio

ice crushers

PATENTED

- Permette di ottenere il ghiaccio tritato in varie dimensioni con una semplice regolazione del coltello.
- Ghiaccio sminuzzato finemente per le tradizionali granite.
- Ghiaccio in dimensioni più grandi per la preparazione di cocktail o per guarnire piatti freddi di portata o esposizione.
- Micro di sicurezza sulla bocca di carico.
- Micro di sicurezza sulla vaschetta di raccolta del ghiaccio.
- Bocca in alluminio brillantato.
- Componenti e minuterie in acciaio inox.
- Struttura portante in alluminio e acciaio.
- Mantello e vaschetta di raccolta in materiale plastico termoformato alimentare.
- Cinghia multirighe a basso assorbimento di potenza.

- Allows to crush ice in different sizes by adjusting the blade.
- Finely crushed ice for the traditional Italian granitas.
- Flakes for frozen cocktails or to serve or display cold dishes.
- Safety microswitch on the feeding mouth.
- Safety microswitch on the collecting tray.
- Polished aluminium feeding mouth.
- Stainless steel parts and details.
- Aluminium and stainless steel internal structure.
- Body and tray are made from thermoformed alimentary plastic.
- Ribbed belt for low power absorption.



Manopola per la regolazione dello spessore di taglio
Cut thickness adjusting knob



Micro su leva
Microswitch on the lever



Vaschetta con micro
Collecting tray with microswitch

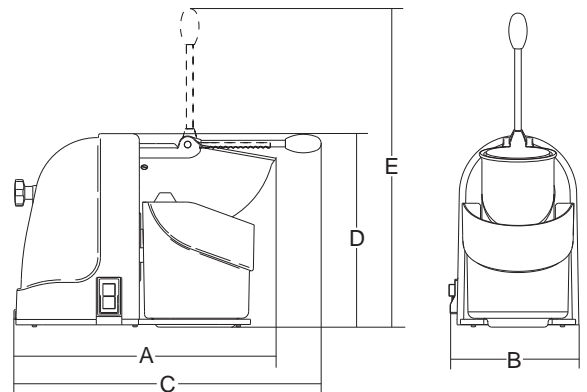

	watt	r.p.m.	r.p.m.	mm	lit	mm	mm	mm	mm	mm	kg	mm	kg	
TRG-S	350	1ph	12.000	1.500	10	2	365	210	465	295	480	8.5	540x280x310	10

TRG-NK

tritagliaccio ice crushers

- Spacca ghiaccio professionale, strumento indispensabile nel bar per la preparazione di drink e frozen, e nel ristorante per l'esposizione di pesce o pietanze fresche.
 - Riduce in scaglie qualsiasi cubetto di ghiaccio prodotto da fabbricatore fino ad una misura di mm 40x40 a -3°C.
 - Previsto di regolazione sullo scarico, permette di gestire la grandezza media delle scaglie
 - Corpo macchina in alluminio estruso, bicchiere in acciaio inox, bocca di lavorazione in ABS alimentare e coltelli ghiaccio in acciaio.
 - Motore ventilato con trasmissione ad ingranaggi, per un servizio prolungato, micro interruttore sul coperchio per la massima sicurezza dell'operatore.
- Professional ice crusher, an indispensable bar tool for preparing drinks and frozen cocktails and in the restaurant for displaying fish or fresh foods.
 - Crushes any ice cubes made with an ice cube machine up to 40x40mm at -3° C.
 - Its discharge adjustment lets you regulate the average size of the crushed ice.
 - Extruded aluminium body, stainless steel container, food-grade ABS opening and s/steel blades.
 - Ventilated motor with gear transmission for prolonged use, micro-switch on the lid for maximum operator safety.









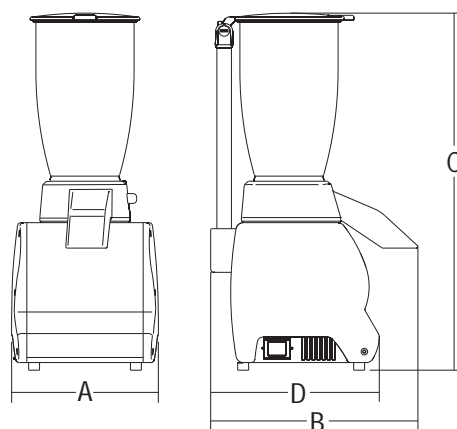





Leva per la regolazione dello spessore del ghiaccio
Adjustable lever ice thickness



Coltelli
Blades



												
	watt	1ph	r.p.m.	lt	lt	mm	mm	mm	mm	kg	mm	kg
TRG-NK	150	1ph	800	3	2	205	285	491	235	5.2	410x280x560	8

SA

spremiagrumi citrus juicers

- Spremiagrumi professionale dal design piacevolmente arrotondato adatto per un utilizzo intenso in tutti i bar che necessitano di una lavorazione semplice ed intuitiva.
- Corpo macchina bianco o cromato, privo di angoli e giunzioni per facilitare la pulizia.
- Vasca di lavorazione in acciaio inox rimovibile per la pulizia ed il lavaggio anche in lavastoviglie; a richiesta vasca in ABS dalle generose dimensioni e una maggiore economicità della macchina.
- Setaccio mobile con due dimensioni di pigna per adattarsi a tutti i tipi di agrume.
- A richiesta versione con leva in alluminio e acciaio inox per lavorare senza sporcarsi le mani.
- Microinterruttore brevettato sulla pigna che permette di accendere direttamente la macchina premendo l'agrume. Su richiesta senza microinterruttore per una maggiore economicità della macchina.
- Variatore di velocità a richiesta.



SA



SA LEVA

- *Commercial easy to use citrus juicer with round design.*
- *White or chrome body, no edges or seams for easy cleaning.*
- *Stainless steel bowl is removable for cleaning and is dishwasher safe, ABS bowl available on request.*
- *Removable sieve with reamer in two sizes to squeeze any kind of citrus.*
- *Aluminium stainless steel lever to avoid any food contact is available on request.*
- *Patented safety microswitch on the cone allows to activate the juicer when the product is pushed down.*
- *Speed control on request.*



Setaccio con 2 pigne
Sieve with 2 reamers



Pigna piccola e grande
Small and big reamer



Opzionale: coperchio
Optional: Lid

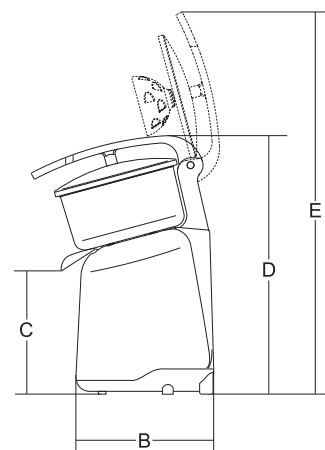
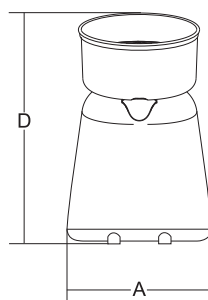

	watt/HP	1ph	r.p.m.	mm	mm	mm	mm	mm	kg	mm	kg
SA ECO	150/0.20	1ph	320	210	210	155	310	-	2.5	270x340x370	3.5
SA	150/0.20	1ph	320	210	210	155	290	-	3	270x340x370	4
SA VV	150/0.20	1ph	280 ÷ 750	210	210	155	290	-	3	270x340x370	4
SA Leva	150/0.20	1ph	320	210	265	155	330	480	3.5	270x340x370	4.5
SA Leva VV	150/0.20	1ph	280 ÷ 750	210	265	155	330	480	3.5	270x340x370	4.5

SA GR

spremiagrumi citrus juicers



SA GR LEVA



SA GR

- Imponente e prestante, adatto a grossi carichi di lavoro.
- Struttura in alluminio anodizzato.
- Vasca e leva in acciaio inox Aisi 304.
- Potente motore ventilato con riduzione ad ingranaggi.
- Setaccio mobile con due dimensioni di pigna per adattarsi a tutti i tipi di agrume.
- Microinterruttore su pigna di serie.
- Variatore di velocità opzionale.
- Pratico sottobicchiere salvagoccia.

- *Imposing, efficient, heavy-duty juicer.*
- *Anodized aluminium frame.*
- *AISI 304 stainless steel bowl and lever.*
- *Powerful ventilated motor with gear drive.*
- *Removable sieve with reamer in two sizes to squeeze any kind of citrus.*
- *Standard microswitch on the reamer.*
- *Optional speed control.*
- *Practical mat.*

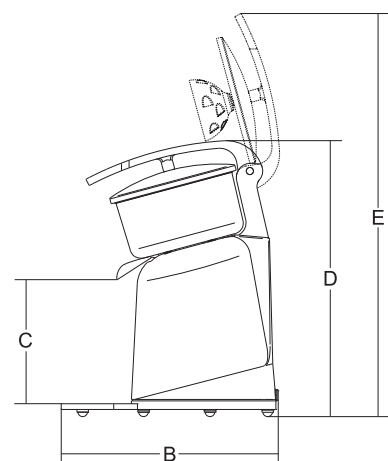
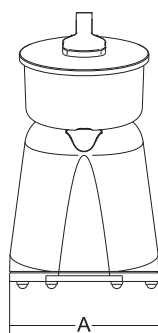
Setaccio con 2 pigne
Sieve with 2 reamersPigna piccola e grande
Small and big reamer

	watt/HP	1ph	r.p.m.	mm	mm	mm	mm	mm	kg	mm	kg
SA GR	150/0.20	1ph	320	210	300	173	355	-	5	390x300x440	6
SA GR VV	150/0.20	1ph	280+750	210	300	173	355	-	5	390x300x440	6
SA GR Leva	150/0.20	1ph	320	210	300	173	385	570	6	390x300x440	7
SA GR Leva VV	150/0.20	1ph	280+750	210	300	173	385	570	6	390x300x440	7

GRP

gruppi bar modulari
modular bar groups

- Corpo macchina in alluminio estruso e fianchi in ABS.
- Potenti motori con ventilazione forzata.
- Frullatore, frappé, rompighiaccio e spremiagrumi mantengono le caratteristiche tecniche e originali della macchina singola.

AL = spremiagrumi con leva
OQ = frullatore con bicchiere Quadro
N = rompighiaccio
S = frappé

- *Extruded aluminium machine body and sides in ABS.*
- *Powerful motor with forced ventilation.*
- *Blender, drink mixer, ice crusher and citrus juicer have the same technical and original features as the individual machines.*

AL = citrus juicers with lever
OQ = blender with square glass
N = ice crushers
S = drink mixers



GRP 1 AL



GRP 2 ALOQ



GRP 2 ALN



GRP 2 OQN



GRP 3 ALOQN



GRP 4 ALOQNS



Setaccio con 2 pigne
Sieve with 2 reamers









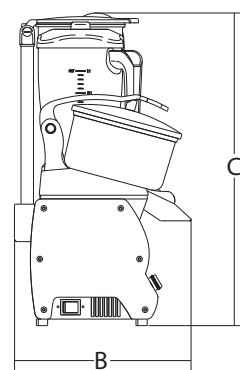
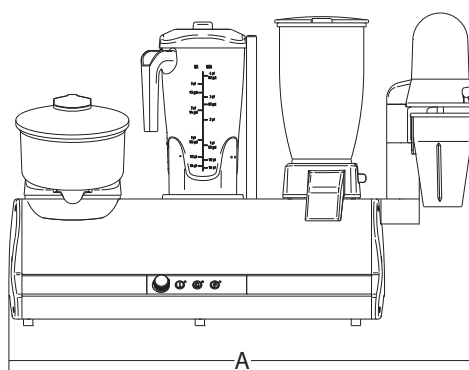

Bicchieri intercambiabili facilmente smontabili per la pulizia
Disassembled and interchangeable glasses, easy to cleaning



Bicchieri quadri impilabili
Stackable square glass



									
	watt	1ph	r.p.m.	mm	mm	mm	kg	mm	kg
GRP 1 AL	150	1ph	320	202	242	370	4.2	290x380x395	6
GRP 2 ALOQ	150/750	1ph	320/8.000 ÷ 16.000	402	242	486	9.2	380x500x590	11
GRP 2 ALN	150/150	1ph	320/800	402	283	495	9.5	380x500x590	11.5
GRP 2 OQN	750/150	1ph	8.000 ÷ 16.000/800	402	283	495	10.2	380x500x590	12
GRP 3 ALOQN	150/750/150	1ph	320/8.000 ÷ 16.000/800	602	283	495	13.7	380x705x590	16
GRP 4 ALOQNS	150/750/150/100	1ph	320/8.000 ÷ 16.000/800/14.000	747	283	501	16.5	380x840x590	18.5